



Hands free operation helps reduce the risk of cross contamination and blood borne pathogens



Taking control of today's environmental hygiene concerns with hands free solutions



- Introducing the Frost Code 625, a hands free feminine napkin disposal unit, available in a low maintenance slim profile design.
- Provide your employees, customers or tenants with the hygienic option of hands free and worry free restrooms.
- Protect your hands from possible contact with harmful germs and contaminated surfaces.



Frost Products Ltd.
5280 John Lucas Dr. Burlington ON L7L 5Z9
ph. 905.332.5700 fax. 905.332.7105
www.FrostPL.com info@FrostProductsLtd.com



Hands Free Napkin Disposal

Code 625: Hands free napkin disposal unit, stainless steel
Overall dimensions in inches, (centimeters in brackets).



Sanitary Disposal Unit

Hands free operation helps reduce the risk of cross contamination and blood borne pathogens

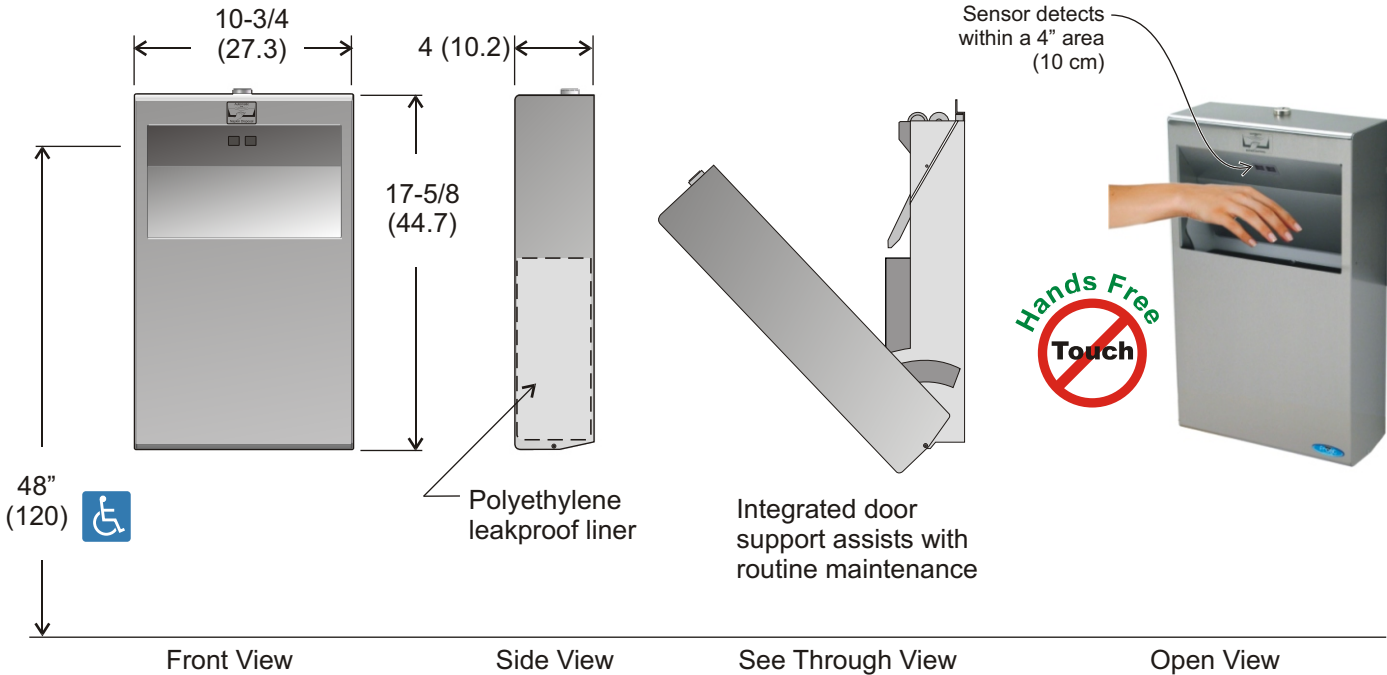

Specifications

Site location:

Dispensing:

Materials:

Shipping Weight:

Installation:



- Ideal for high traffic areas requiring hands free operation.
- Door is opened when hand is placed within 4" (10 cm) of sensor in door opening area and remains open for 5 seconds there after. Counterbalanced door swings freely in the event of depleted or missing batteries.
- Unit is powered by 4 "c" alkaline batteries (not included).
- Battery life is 10,000 cycles, or 2 years.
- Polyethylene leakproof liner capacity: 5.1 litres. (1.1 imp. gal.)
- All metal construction, stainless steel cover all design.
- 8.5 lbs. (4 kg).
- For unrestricted access, sensor area of unit to floor should not exceed 48" (120 cm). Mounting screws and instructions included.